

IO Controller: HWg-ER88a

RS-232/485 serial port, 8 input contacts, 8 outputs, Ethernet

I/O Controller enables monitoring of binary inputs as well as control of outputs and the serial line remotely over TCP/IP and Ethernet.

Serial port, inputs and outputs are controlled with a TELNET-like (RFC2217) M2M protocol. The protocol is fully documented. Use the Hercules terminal SW for testing.

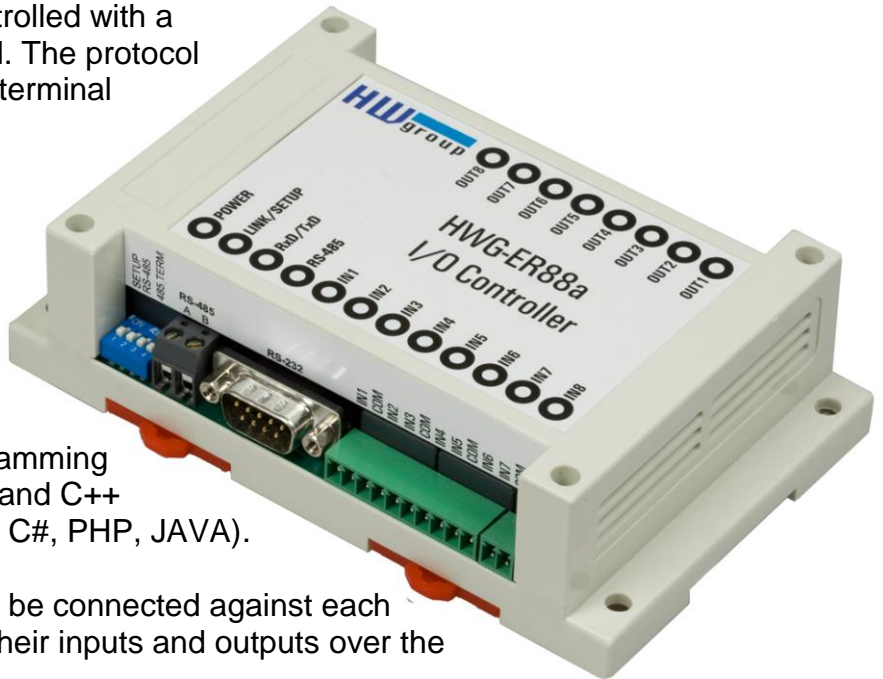

- ✓ Redirect ER88a serial port to a **virtual serial port** (e.g. COM27) on any networked PC. The **HW VSP** application for Windows is supplied free of charge.
- ✓ Accelerate your deployment with many examples for various programming languages in the **HWg SDK** (Borland C++ Builder, MS Visual C, VB, Delphi, C#, PHP, JAVA).
- ✓ **Box-2-Box mode:** Two units can be connected against each other in order to interconnect all their inputs and outputs over the Ethernet, including the serial line.

Applications

- Easily connect a barcode reader or a serial printer over an IP network (LAN / WAN).
- Link up to eight buttons with a SW application.
- Control a gate, a horn, or an alarm signal using the outputs that can be boosted with external relays.

Basic features of IP HWg-ER84a

- Industrial model, fits on a DIN rail
- Serial RS-232/RS-485 port
- 8 binary outputs (open collector)
- 8 binary inputs to connect Dry contacts, buttons, or external voltage
- Virtual serial port driver for Windows lets you easily have e.g. COM 5 on your PC

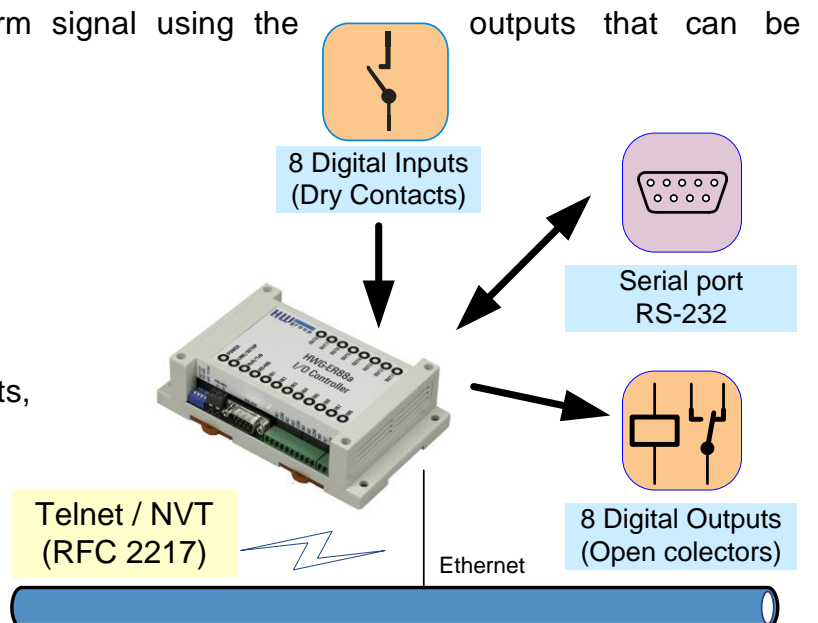

SW applications

- **Virtual Serial port**

HW VSP (Virtual Serial Port) creates a virtual COM port (e.g. COM27) on the PC and ties it with the serial port on the unit.

Runs as a NT service (can be used on Windows servers).

- **HW VSP Single licence** for Windows 2000/XP/Vista is free.
- **HW VSP Multi licence** creates up to 64 virtual ports on a single PC and ties them with up to 64 IP Relay, PortBox, I/O Controller and/or PortStore units.



- **Hercules** – Handy debugging and testing utility, I/O support

- **HWg IPRC cmd** – Command-line control of outputs

- **HWg SDK examples**

Software Development Kit is available for download free of charge.

- EX01: UDP Setup (Borland C++ Builder, MS Visual C, VB, Delphi, C#)
- EX02: I/O Controller (Borland C++ Builder, MS Visual C, VB, Delphi, C#)
- EX03: Control Remote Serial Port (Borland C++ Builder, MS Visual C, VB, Delphi, C#)
- EX13: TCP Setup (Borland C++ Builder, MS Visual C, VB, Delphi, C#)

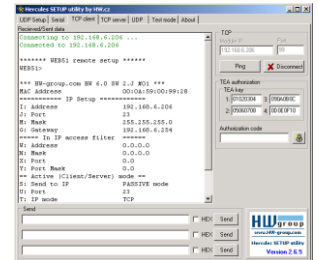

Technical specifications	
Ethernet	RJ 45 – 10BASE-T / 10 Mbps
+ Protocols	TCP/IP, UDP/IP, Telnet+RFC2217
+ Modes	TCP Server, TCP Client/Server, UDP (serial port only)
+ Security	Authorized IP range / TEA (128B) authentication
+ Configuration	RS-232 Setup (9600 8N1) Telnet Setup (over IP, port 99) UDP Config (over IP, UDP broadcast, Hercules / UDP Config utility)
Serial port	RS-232 (Cannon DB9M – Rx, Tx, CTS, RTS, GND) RS-485 (Ø3mm terminals)
Inputs	8 contacts (external voltage 0 / 3..12V DC)
Outputs	8 outputs (darlington transistors) common ground, 50VDC / 0.5A / 2W max for all 8 outputs
Power	8–24VDC / 0.25A (barrel connector, terminal block)
Dimensions / Fixing	25 x 82 x 90 [mm] / DIN rail, wall mount
Conditions	Operating: -10°C .. +60°C / 10 %RH .. 80%RH

Product ordering numbers		
600 354	HWg-ER88a	I/O Controller ER88a unit only, no power adapter or cables.
600 383	HWg-ER88a SET	Recommended set for getting acquainted with the product. Contains: ER88a, power adapter, cables, CD, etc.

M2M mode

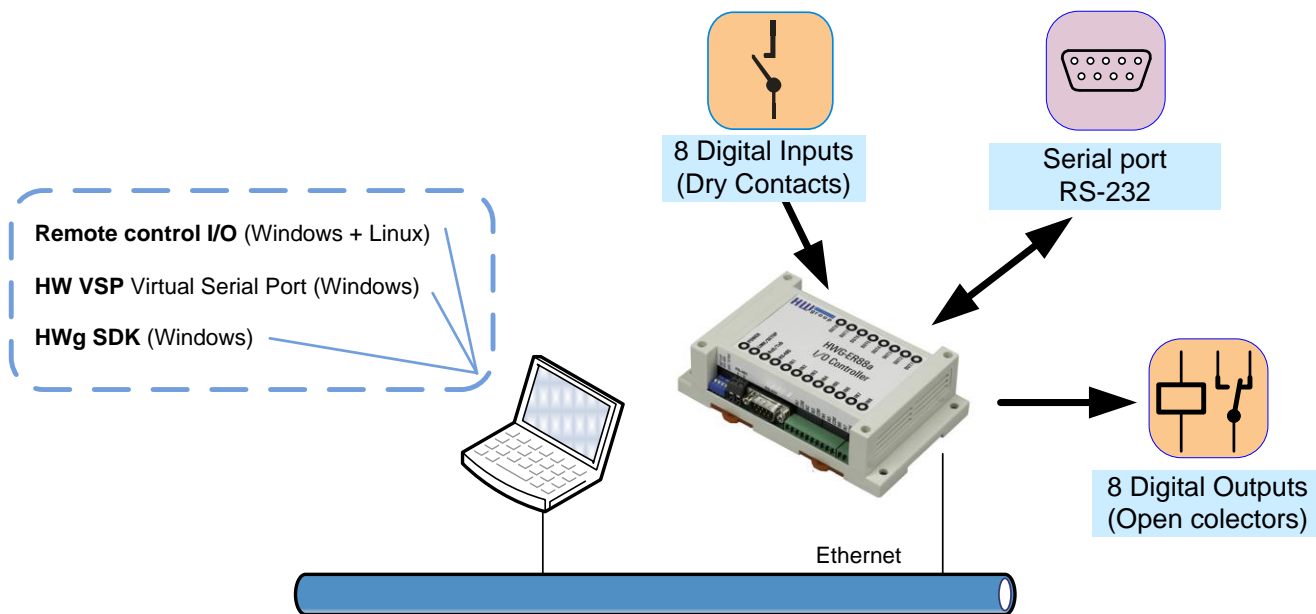

Box-2-Box mode

